



Australian Government

**Australian Quarantine
and Inspection Service**

Requirements for Pasteurisers Under the Export Control

Milk and Milk Products Orders 2006

**Presented by
Jalal Dean
Senior Dairy Auditor
Dairy Review Unit
AQIS South Australia**

Legislative Requirements

- Export Control Act (Milk and Milk Produce) Orders 2005

- Schedule 5, DIV 111



Orders 16.1 -17.2 state the requirements for pasteurisers and other heat treatment for liquid milk and milk products for export.

- Dairy Export Operations Manual (DEPOM) is used by AQIS officers during audits of export plants.

AQIS Work Procedures

- AQIS auditors follow:
 - Dairy Export Operations Manual (DEPOM)
15.1 to assess various aspects of a pasteuriser
- For pasteuriser suitability DEPOM references :
 - ANDASC “Validation of Pasteurisers and pasteurisation”
 - NZFSA D121.1 Dairy Treatment Standards
 - AS 3993.2003 Equipment for the Pasteurisation of Milk and Other Liquid Products –Continuous Flow Systems.

What do AQIS Officers check during audits?

- Validation or evidence to ensure pasteurisation or its equivalence.
- Evidence from a reputable source that the pasteuriser and all other devices comply.

Some of the things we check!

- Records of charts/recording device which clearly show:
 - pasteurisation temperatures
 - holding times
 - diversion checks (alarms)
 - pressure differentials (where applicable)
 - calibration of key devices such as thermometer pressure
 - routine maintenance checks for cracks or leaks in plates
- Other checks include :
 - training of key staff operating the pasteuriser
 - effective cleaning and sanitisation of the pasteuriser and associated lines/equipment
 - general physical state of equipment
- Other log sheets/ production records

Important Controls to Consider When Inspecting a Pasteuriser

- Constant Level Tank
- Indicating Thermometer
- Chart Recorder
- Timing Pump
- Holding Tube
- Flow Diversion Device
- Vacuum Breaker (optional)
- Other points

**** please refer to handout 2 & 3**

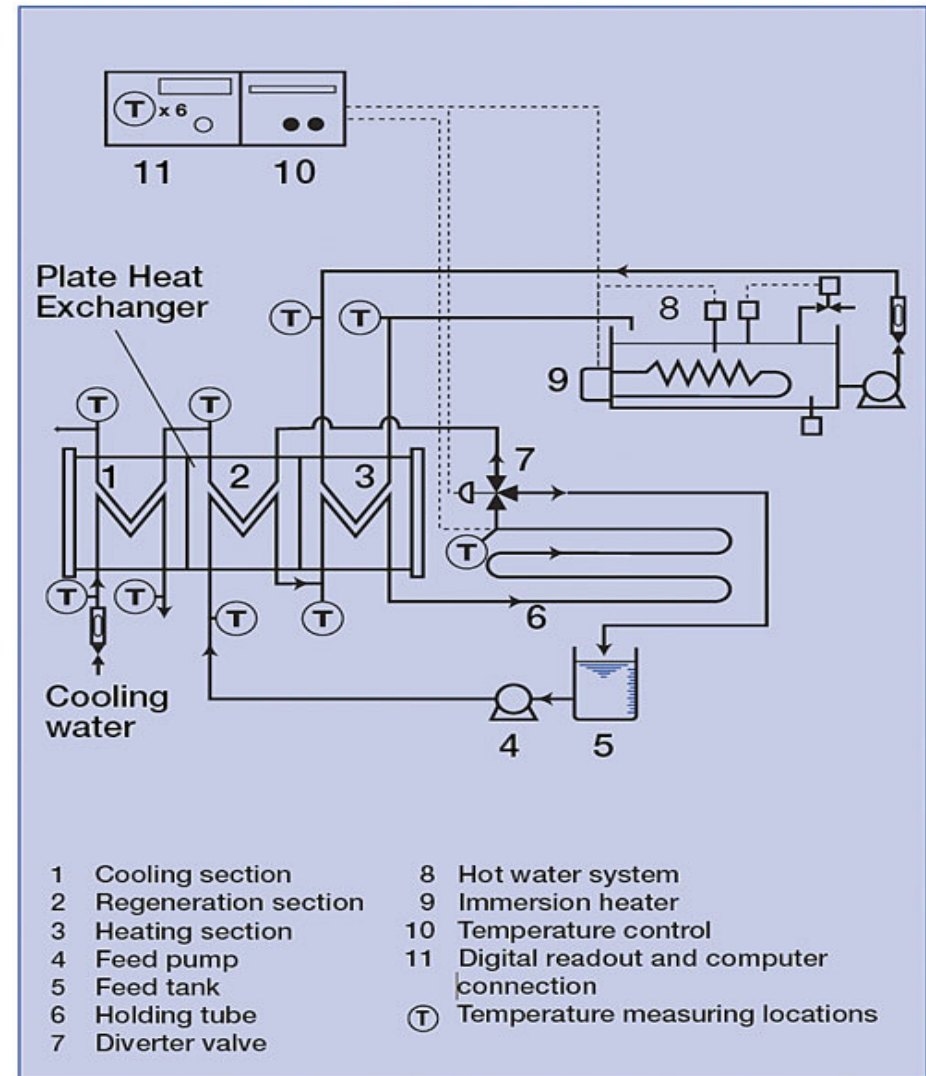

Schematic diagram of Laboratory Pasteuriser

Summary

- Does your pasteuriser **COMPLY** to any one of the following:
 - 1) Designed to meet AS 3993.2003
 - 2) ANZASC –Validation of Pasteurisers and Pasteurisation
 - 3) Any other validation from a reputable source **TO VERIFY** that every particle of milk has gone through pasteurisation as per defined in orders 16.1 and 17.1

Common Problems During Audit

- See handout 3
- Open Discussion